



---

**AIR  
POLLUTION  
CONTROL  
PRODUCTS &  
SYSTEMS**

---



---

**B E T T E R   A I R   I S   O U R   B U S I N E S S <sup>®</sup>**

---



# AIR POLLUTION CONTROL PRODUCTS & SYSTEMS

## UNMATCHED PRODUCT LINE AND APPLICATION EXPERIENCE

Modern industrial processes produce large quantities of airborne pollutants in all forms – particulates, gases, vapors, fumes and mists. Many are toxic and concentrations generally far exceed safe levels of exposure to workers. Reducing the concentration to acceptable levels identified by the American Conference of Governmental Industrial Hygienists (ACGIH) is a critical factor in the operation of any industrial process.<sup>(1)</sup>

Design of the overall plant ventilation system must take into consideration a complex series of factors:

- Controlling the level of process generated contaminants
- Employee health and comfort
- Temperature and humidity control
- Supply and exhaust air balance
- EPA regulations for discharging exhaust air
- The risk of dust generated explosions
- Cost of the air pollution control equipment
- Cost of the HVAC equipment
- Operating costs of the system

AAF International has an unmatched capability to understand complex air pollution control problems and to develop effective solutions from conception through final installation. Our complete line of equipment allows us to recommend the most efficient and economical solutions ranging from a completely packaged unit to solve small in-plant dust control problems up to large, complex, custom engineered systems for major air pollution control projects.

AAF International has pioneered many of the techniques and equipment used in air pollution control applications today. AAF's dust, mist, vapor and fume control products can be found in thousands of installations in virtually every industry and in most industrialized countries around the world.

<sup>(1)</sup> Refer to the ACGIH Industrial Ventilation Manual and 2002 TLVs and BEIs, copyright 2002 Cincinnati, OH

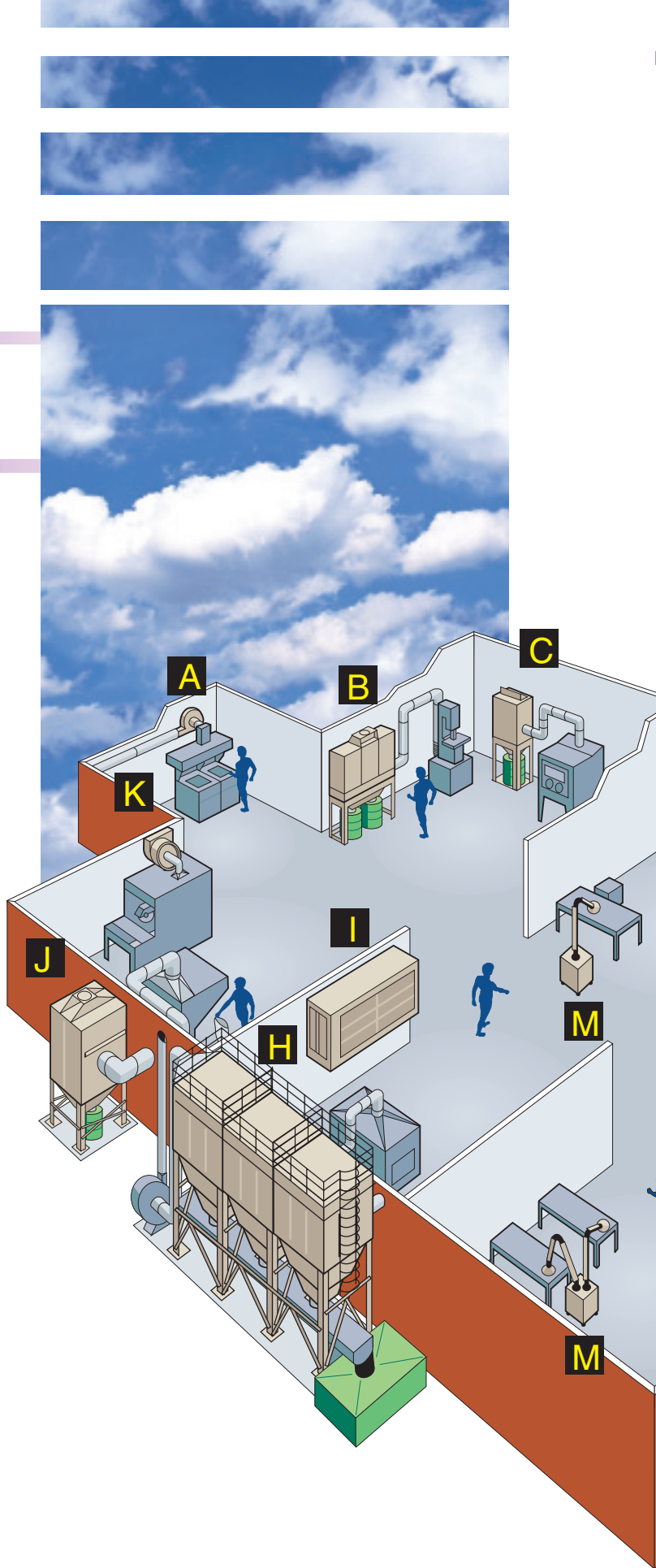



W RotoClone



OptiFlo



OptiFlo ECB



OptiFlo

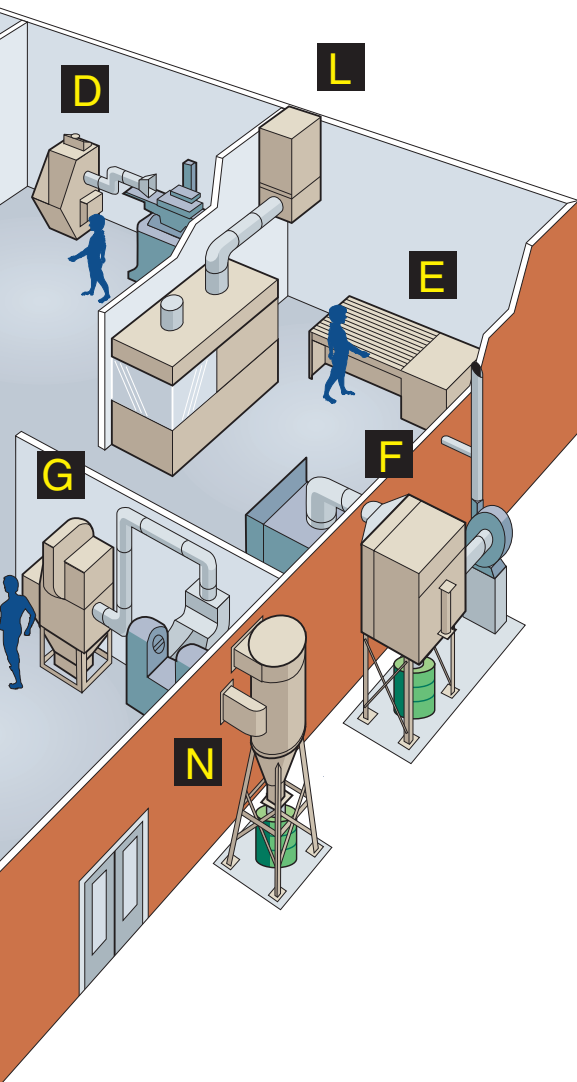

- A Commercial Range Hood Exhaust**  
Type W RotoClone wet centrifugal collector serves as a grease collector, exhaust fan and fire barrier. Page 4
- B Woodworking**  
ArrestAll fabric collector removes wood dust and shavings from a woodworking station. Page 5
- C Sandblasting**  
DustCatcher self-contained cartridge collector for direct source capture of sandblasting operation. Page 6
- D Light Metal Grinding**  
Type N RotoClone Model LV wet collector captures particulate from an aluminum grinding operation. Page 4
- E Metal Grinding Workstation Bench**  
Downdraft Bench cartridge collector removes filings and other particulate from a ferrous metal grinding workstation. Page 6
- F Thermal Spray Operation**  
OptiFlo pulse-jet cartridge collector captures over spray from an arc spraying metallizing process. Page 6
- G Ferrous Grinding**  
Type N RotoClone collects discharge from tool room grinding operation. Page 4
- H Boiler Fly Ash**  
FabriPulse and Millennium fabric dust collectors remove flyash from coal fired boiler. Page 5
- I General Plant Air Cleaning and Fugitive Fume Capture**  
Side Access Filter Housings clean and recirculate air inside the plant. Page 8
- J Material Handling**  
Design M FabriPulse fabric collector collects particulate in a material handling operation. Page 5
- K Oil Mist**  
DynaPure mist collector removes mist generated by a machining operation. Page 7
- L Oil Mist and Smoke**  
The OilPak is used for the elimination of lubricant mist and smoke resulting from high speed wet machining, cutting, and grinding operations. Page 7
- M Weld Fume Collectors**  
Portable weld fume collectors are used to capture weld smoke and fumes at the source and can be conveniently moved around the plant. Page 7
- N Cyclones**  
AAF Cyclones provide an economical method of controlling large dust particles from woodworking and steel grinding operations. Page 8

## WET COLLECTORS

AAF International engineered the development of wet collectors which are devices designed to remove particulate matter from the air by passing them through a liquid medium. AAF supplies wet collectors for a wide range of applications from small nuisance dust problems to extremely large gas cleaning systems.

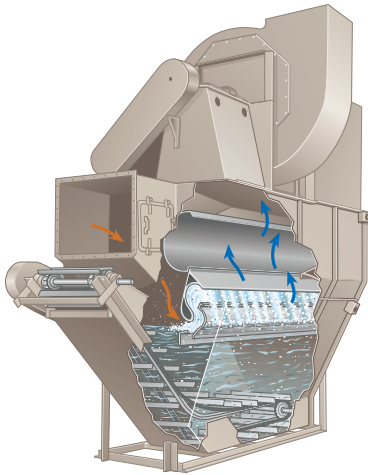

Type N RotoClone

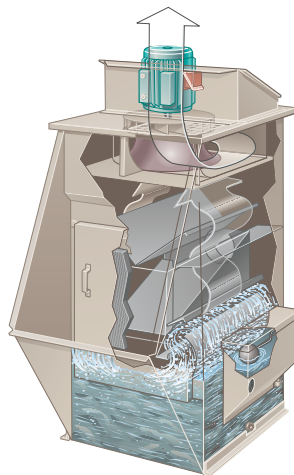

Type N RotoClone Model LV

### TYPE N ROTOCLONE® MODEL LV

The Type N RotoClone Model LV dust collector is specifically designed for the ventilation and pollution control of dust emitting machines that require air volumes under 2,000 CFM. It is available in four sizes: 500, 1,000, 1,500 and 2,000 CFM. The Model LV collector can be close coupled to the dust sources or remotely located with connecting ductwork. The source capture and dust removal features of the Model LV allow recirculation of in-plant air.

The Model LV is a completely self-contained dust collecting device, including fan, motor, and water level controls. When coupled with its optional downdraft bench, it provides an industrial worktable that is suitable for explosive metal (A1, Ti, Mg) grinding and polishing.

Brochure APC-1-519

### TYPE N ROTOCLONE®

The Type N RotoClone cleans the air by the combined action of centrifugal force and a thorough intermixing of water and dust-laden air. It has no moving parts, pumps, or other auxiliary equipment; requires minimum space and is easy to install. The collector is furnished in three arrangements – manual sludge removal, continuous sludge ejection (shown here) and continuous sludge sluicing. The Type N satisfies NFPA requirements for collection of light materials such as aluminum, titanium and magnesium. Available for volumes of 900 to 57,600 CFM.

Brochure APC-1-511

### KINFACTOR®

The KinFactor scrubber uses a venturi-type orifice for intermixing of dust particles and water. This intermixing is accomplished by rapid contraction and expansion of the airstream and a high degree of turbulence. Dust is collected through the principle of impaction. The KinFactor is generally designed to use 8 GPM of scrubbing water per 1,000 CFM of saturated gas at the throat. Available for saturated volumes of 500 to 60,000 CFM.

The KinFactor is used wherever high pressure drop venturians are necessary to collect submicron particulate or exceptionally high efficiency is required.

Brochure APC-1-514

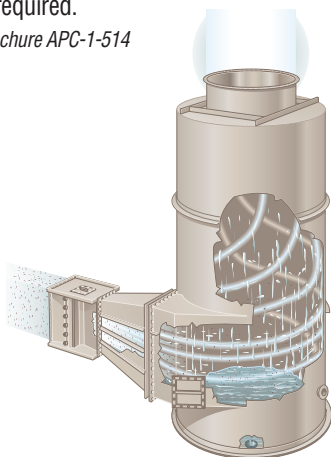

Type KinFactor

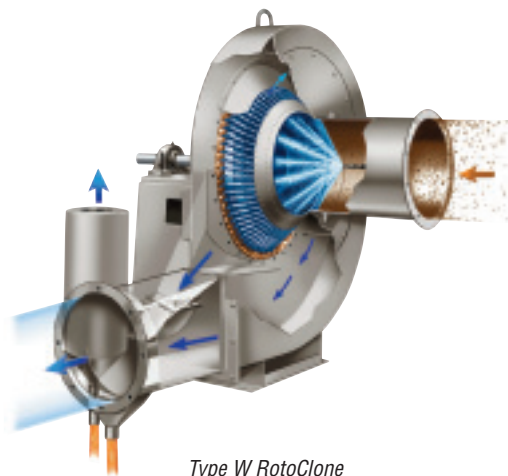

Type W RotoClone

### TYPE W ROTOCLONE®

The Type W RotoClone is designed to combine the scrubbing effect of water with the principle of dynamic precipitation. It is a highly effective wet type collector which discharges collected materials as a slurry with a minimum water requirement (only 1/2 to 1 gallon per 1,000 CFM of air). The Type W collector is effective on applications such as chemical processing, metal mining, coal processing, sand and die casting, food processing, and pharmaceutical dust capture. Available for volumes of 1,000 to 50,000 CFM.

Brochure APC-1-512

## FABRIC COLLECTORS

One of the more universally applied air pollution control devices is the fabric collector which removes particulate matter from the gas stream through the filtration action of special fabric materials.

### ARRESTALL™

The AAF ArrestAll self-contained dust collector is a shaker type fabric collector which offers an inexpensive, compact solution to dust control problems. It is economical to operate, simple to maintain, and requires minimum floor space in addition to providing cleaning efficiencies of 99+% by weight. This extremely high cleaning efficiency permits recirculation of the air back to the work area in almost all cases, resulting in considerable savings by eliminating the need for additional make-up air. Available in sizes from 150 to 11,500 CFM.

*Brochure APC-1-240*



*ArrestAll*

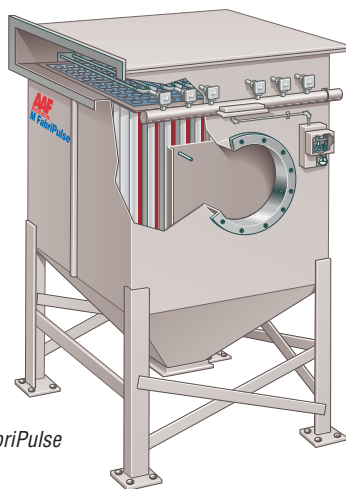

*Design M FabriPulse*

### MILLENNIUM™

AAF is a major supplier of pulse-jet dust collectors, with thousands of installations of FabriPulse collectors. The Millennium combines the most outstanding features of the FabriPulse with AAF product development ideas to meet the increasing demands for higher quality air for people, products, processes and equipment in the 21st century.

The Millennium is modular in design. The modules are available in different heights and can accommodate a range of fabric bag lengths, as well as pleated bags. Since each Millennium will be constructed from modules, there is almost no limit to the size of the collector.

*Brochure APC-1-405*



*Millennium*

### DESIGN M FABRIPULSE™

The Design M FabriPulse pulse-jet fabric dust collector was designed to fill the need of those industrial dust collection applications that require small, compact filter sizes and low air volumes. It is suitable for low headroom indoor applications as well as for outdoor installation. Available in sizes from 100 to 1,500 square feet of cloth area, the Design M collector is suitable for pharmaceutical, powder paints, woodworking, metal machining, and other dust producing applications.

It features bag lengths of 4 and 6 feet, a housing and hopper constructed of 12 gauge steel, and a specially designed bag in a cartridge assembly that can be easily changed. Installation worries are eliminated since the collector ships with bags installed on all sizes through size 6-252.

*Brochure APC-1-411*

## CARTRIDGE COLLECTORS

Cartridge collectors utilizing multiple cartridges made of pleated media in a cylindrical configuration are among the most popular collector designs currently on the market. They are highly effective on dry particulate.

All OptiFlo products use OptiKlean cartridges for maximum performance.

### OPTIFLO™

The OptiFlo cartridge collector system is a completely modular design that allows an unlimited range of sizes. Modules can be interconnected to accommodate the largest air cleaning task. The compact modules conserve valuable space.

OptiFlo units have the lowest flange-to-flange pressure drop, allowing up to 10% greater airflow with lower fan horsepower than competitive models. The OptiFlo design permits free-fall of dislodged particulate into the hopper without direct impingement of contaminant on the cartridges which minimizes abrasion and dust build-up.

A wide selection of cartridge types, options and accessories enable the collector to be tailored to specific application requirements. Choose from top or side inlet/outlet arrangements.

*Brochure APC-1-102*

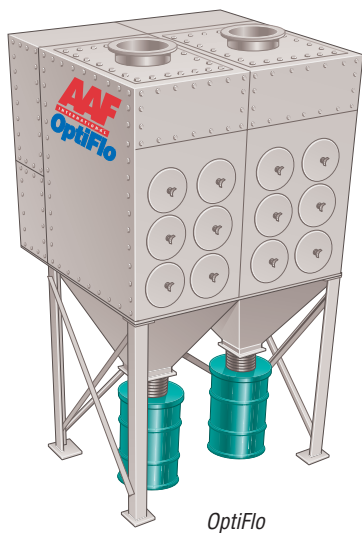

OptiFlo



OptiFlo  
DustCatcher

### OPTIFLO™ DOWNDRAFT BENCH

AAF OptiFlo downdraft benches are designed to capture fumes, smoke and nuisance dust from sanding, grinding and de-burring operations. Tops are made from steel with optimum spacing engineered to capture the maximum amount of contaminant.

The benches come in 5 and 7 foot lengths and with 6 high efficiency cartridge filters to maximize contaminant capture. A manually operated, built-in pulse system is standard for cleaning the cartridge filters. An optional back wall is available.

*Brochure APC-1-269*



Downdraft Bench

### OPTIFLO™ DUSTCATCHER

The DustCatcher is a compact, self-contained cartridge collector designed for lower air volume applications. The cartridges are automatically cleaned by reverse pulsing allowing continuous duty operation.

A wide variety of arrangements and sizes are available with capacities up to 3,000 CFM. The units handle up to 35% more airflow capacity and use up to 1/3 less horsepower than competitive models. The DustCatcher is designed to serve a single source or a ducted system of multiple sources.

The high efficiency pleated filter cartridges are made with a blend of nonwoven media. Optional medias are available for specialized applications. Cartridge replacement is an easy task with full size doors allowing complete access to the cartridge compartment. High efficiency final filters are also available for recirculating processed air back into the plant environment.

*Brochure APC-1-130*

## PORTABLE WELD FUME EXTRACTORS



The AAF Portable Weld Fume Extractors are self-contained, portable units that capture welding smoke and fume at the source. They are convenient and flexible solutions for multiple sources of weld fume/smoke and can be moved around your facility to suit the changing demands of your operation.

All units feature high efficiency cartridge filters and the ability to recycle cleaned air back into the plant. Depending upon the model, the products can also be obtained with pulsed cartridge cleaning, activated carbon filters for gas absorption and in one or two arm configurations. Capacities range from 700 CFM to 1530 CFM and come in 1.5 and 3.0 horsepower models.

*Brochure APC-1-265*

*Brochure APC-1-266*

*Brochure APC-1-267*

## MIST COLLECTORS

Mist collectors provide direct source capture of mist generated by wet machining, spraying and lubrication systems.

Mists must be differentiated from other forms of contaminant and are defined as follows <sup>(1)</sup>:

Mists – Small droplets of materials that are ordinarily liquid at normal temperature and pressure.

Vapors – The gaseous form of substances which are normally in the solid or liquid state and which can be changed to these states either by increasing the pressure or decreasing the temperature.

Gases – Formless fluids which tend to occupy an entire space uniformly at ordinary temperatures and pressures.

Fumes – Small, solid particles formed by the condensation of vapors of solid materials.

*Source: ACGIH Industrial Ventilation Manual, 24th Edition, 2001*

## DYNAPURE®

The DynaPure mist collector is a self-contained filtration system for source control of mist created by wet machining, spraying and lubrication systems. It is a unique, simple method for the elimination of mist problems. A rotating drum collects and agglomerates the mist particles – even submicron particles – in its filtering element. Centrifugal force then drives these particles from the airstream. Capacities from 25 to 1,000 CFM.

*Brochure APC-1-222*

*DynaPure®*



## OILPAK

The OilPak is a self-contained oil mist filtering system consisting of an (optional) inlet plenum, agglomerating filter, drainable bag type final filter and integral fan. Proven in hundreds of applications on wet machining and spraying applications, the OilPak is available in sizes to handle 500, 1000 or 2000 cubic feet of mist laden air per minute.

Liquid mist and smoke is collected inside the filter cartridge pockets during operation, and liquids drains back to the machine or to the inlet plenum, depending on the arrangement. The OilPak collector maintains a constant efficiency over the entire life of the cartridge.

*Brochure APC-1-223*

*OilPak*



## ENVIRONMENTAL CONTROL BOOTHS

The AAF OptiFlo ECB Series is designed to pull air through the work area and into the filtration system and recycle the air back into the plant. The high efficiency cartridge filters trap the dust from your manufacturing operations, like sanding, routing, sawing, polishing and welding. Automatic, pulse cleaning comes standard and the pulse timing is adjustable. The booth can be ordered in a variety of sizes and CFM ratings to meet your needs.

*Brochure APC-1-268*

## AIR FILTRATION

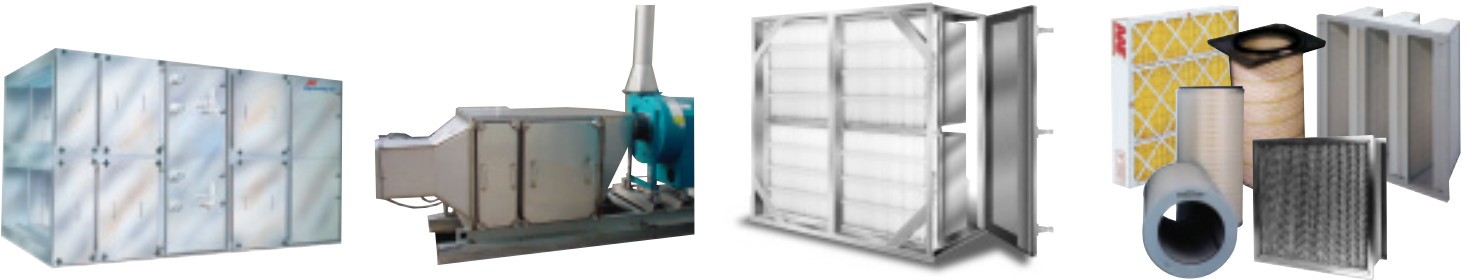

AAF makes a variety of products and systems for removing airborne particulate matter. These include the filter elements and the enclosures to support them. These are generally side access housings and walk-in housings for industrial applications as well as high-integrity systems, for safety applications. The filtration devices are designed to meet diverse applications from protection of heating and cooling coils to preventing the spread of bacteria and removing odors or gases.

## AIR POLLUTION CONTROL EQUIPMENT



AAF dust, mist, and fume control products and systems can be found virtually anywhere large concentrations of airborne pollutants are generated by industrial processes. AAF offers a wide selection of products, permitting the optimum solution to any air pollution problem.

## SPECIALTY ENVIRONMENTAL CONTROL



Highly specialized air cleaning capabilities include protection of turbines and compressors from erosion or fouling, clean room systems, lint and ink mist removal, safety related nuclear power plant systems and diesel engine intake filtration.



10300 ORMSBY PARK PL STE 600  
LOUISVILLE KY 40223-6169  
P O BOX 35690  
LOUISVILLE KY 40232-5690  
[www.aafintl.com](http://www.aafintl.com)

*For Additional Information On AAF Products,  
Call 800.477.1214*

